

CREATE
your STYLE™
with CRYSTALLIZED™ – Swarovski Elements

WIRED SQUARE RING



WIRED SQUARE RING



CRYSTALLIZED™ – Swarovski Elements

Article	Product Group	Article No.	Amount	Size	Color	Color Code	Supplies
	Sew-on Stones	3240	1	12 mm	Crystal	001	Wire, 22 gauge, sterling silver, 40"/3.25 ft. Nylon Beading Thread, 2 mm, Rose or Grey, 18"/1.5 ft.
	Beads	5000	129	2 mm	Vintage Rose	319	
							Tools
							Diagonal cutters
							Round nose pliers
							Chain nose pliers
							Beading needle, size 10 or 12
							Fine-tipped tweezers
							Butane lighter

Prepare the focal piece:

STEP 1

- Using a wire cutters, cut a length of sterling silver wire to 3.
- Using a chainnose pliers, bend one end to a right angle at about 1.75".

STEP 2

- Add on the Art. 3240 with the wire extending upward.
- Underneath, mark the placement for the second right angle bend with your chain nose pliers so that both wire ends will extend upward.
- Remove the crystal and bend the wire at the mark.
- Fit the Article back on both extensions.
- Using a round nose pliers bend each extension down and outward at right angles.

STEP 3

- Trim each end to 5/16" (.8cm) from the top bend.

STEP 4

- Using a round nose pliers, create a plain loop to both ends finishing the ends under each wire extension (leave the top extensions flat until the point where the loops begin).

Create the bezel:

STEP 5

- Cut two pieces of sterling silver wire to 2.5".
- With a roundnose pliers, turn a plain loop to one end of each segment.

STEP 6

- Load 4 Art. 5000 crystals to each segment, the focal piece component loops, and 4 additional Art. 5000 crystals.
- With a wire cutters, trim each end to .25".
- Turn a plain loop to each end orienting the loops to match those at the opposite ends.

STEP 7

- Cut two pieces of sterling silver wire to 3".
- With a roundnose pliers, turn a double-tier loop (two levels of a plain loop resembling a split ring) to one end of each segment.

STEP 8

- Complete the bezel sides by loading one end of each focal component's plain loop, 10 Art. 5000 crystals, and the opposite focal component loop.
- Create double-tier loops to secure each end orienting the loops to match those at the opposite ends.

Create the band components:

STEP 9

- Cut 13 lengths of sterling silver wire to 2".
- With a round nose pliers, turn a plain loop to one end of each segment.
- To 2 of the segments, add 9 Art. 5000 crystals, trim to .25" and turn a plain loop to the end securing the beads within (orient the loops to match the loops at the opposite ends).
- To 4 of the segments, add 8 Art. 5000 crystals and finish as above.
- To 2 of the segments, add 7 Art. 5000 crystals and finish as above.
- To 4 of the segments, add 6 Art. 5000 crystals and finish as above.
- To the final segment, add 5 Art. 5000 crystals and finish as above.

Combine the band and focal components:

STEP 10

- Orient the focal component with the wire extensions at each side.
- Thread the beading thread with a needle. Thread through 1 Art. 5000 crystal, the 5-crystal component, 2 Art. 5000's, 1 6-crystal component, 2 Art. 5000's, 1 6-crystal component, 2 Art. 5000's, 1 7-crystal component; 2 Art. 5000's, 1 8-crystal component, 2 Art. 5000's, 1 8-crystal component, two Art. 5000's and 1 9-crystal component.
- Thread through the top left double tier-loop of the focal component.
- Double back through all the crystal components and Art. 5000's.

- Picking up the tail, thread through the remaining components in the same order as above (omitting the 5-crystal component step).
- Thread through the top right double-tier loop of the focal component.
- Double back through as before, ending after one Art. 5000 crystal on the opposite side of the 5-crystal band component.*

Complete the ring:

STEP 11

- Pull up the slack and tie a surgeon's knot around the thread close between the crystals.
- Trim tail to 3/8" (10mm).
- Hold a fine-tipped tweezers just above the knot and burn a ball-knot to the end by holding a lit butane lighter just next to the end of the tail.
- Repeat the threading steps to create the opposite side of the band and finish the ring.

STEP 1

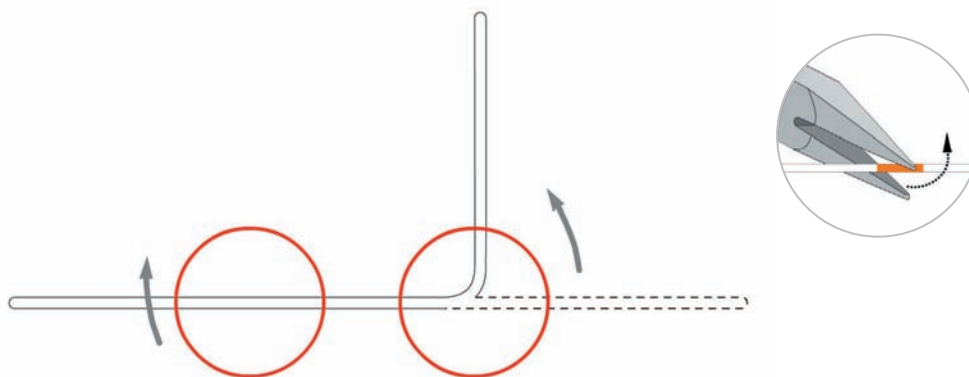

STEP 2

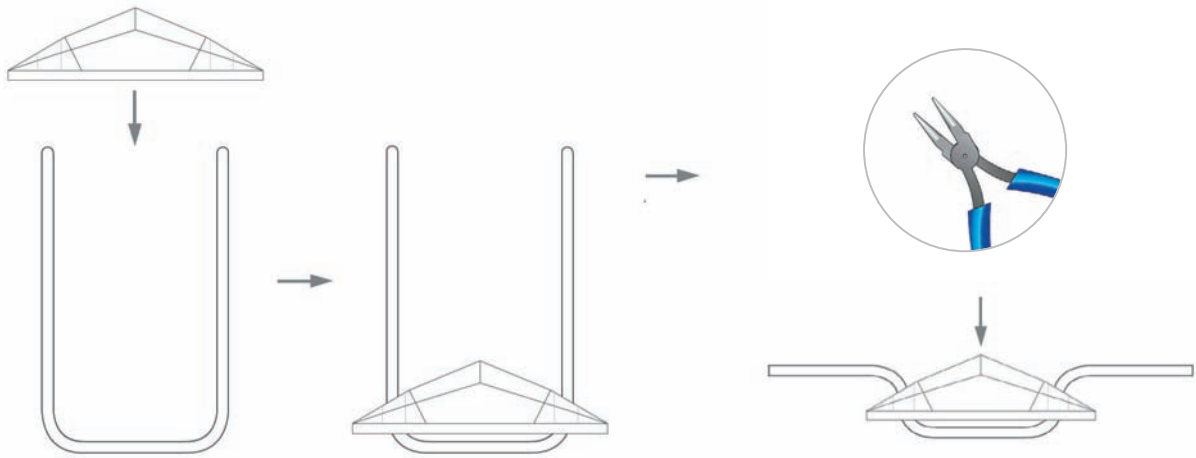

STEP 3

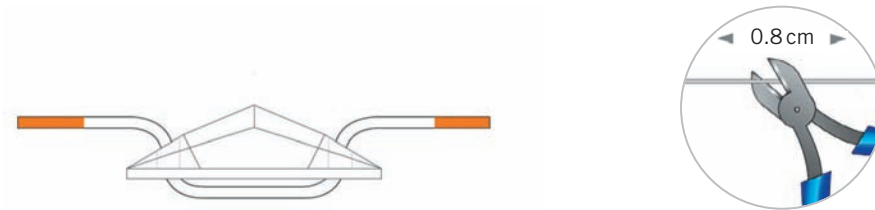

STEP 4

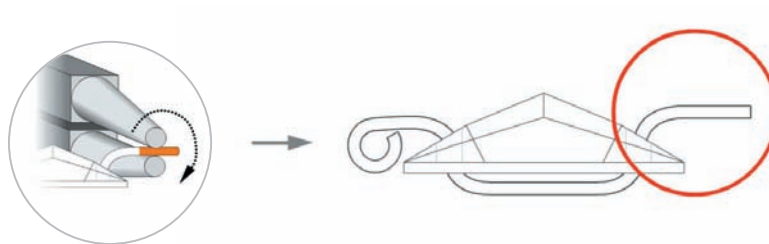

STEP 5

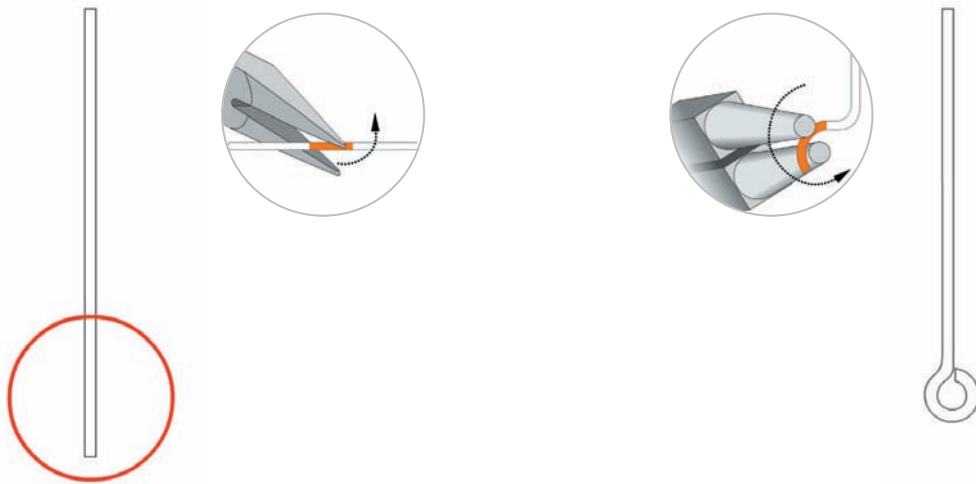

STEP 6

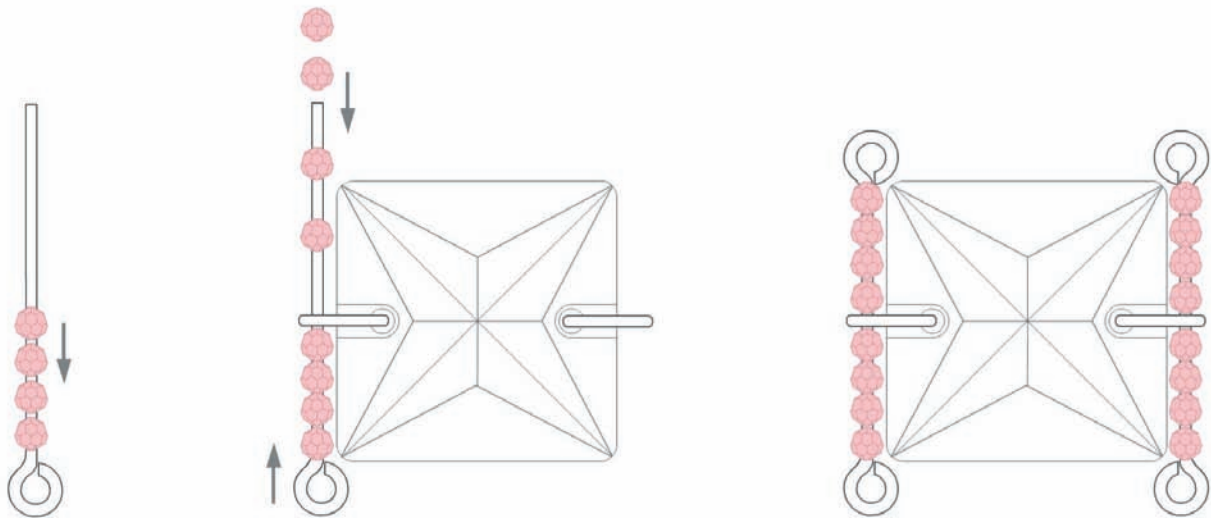

STEP 7

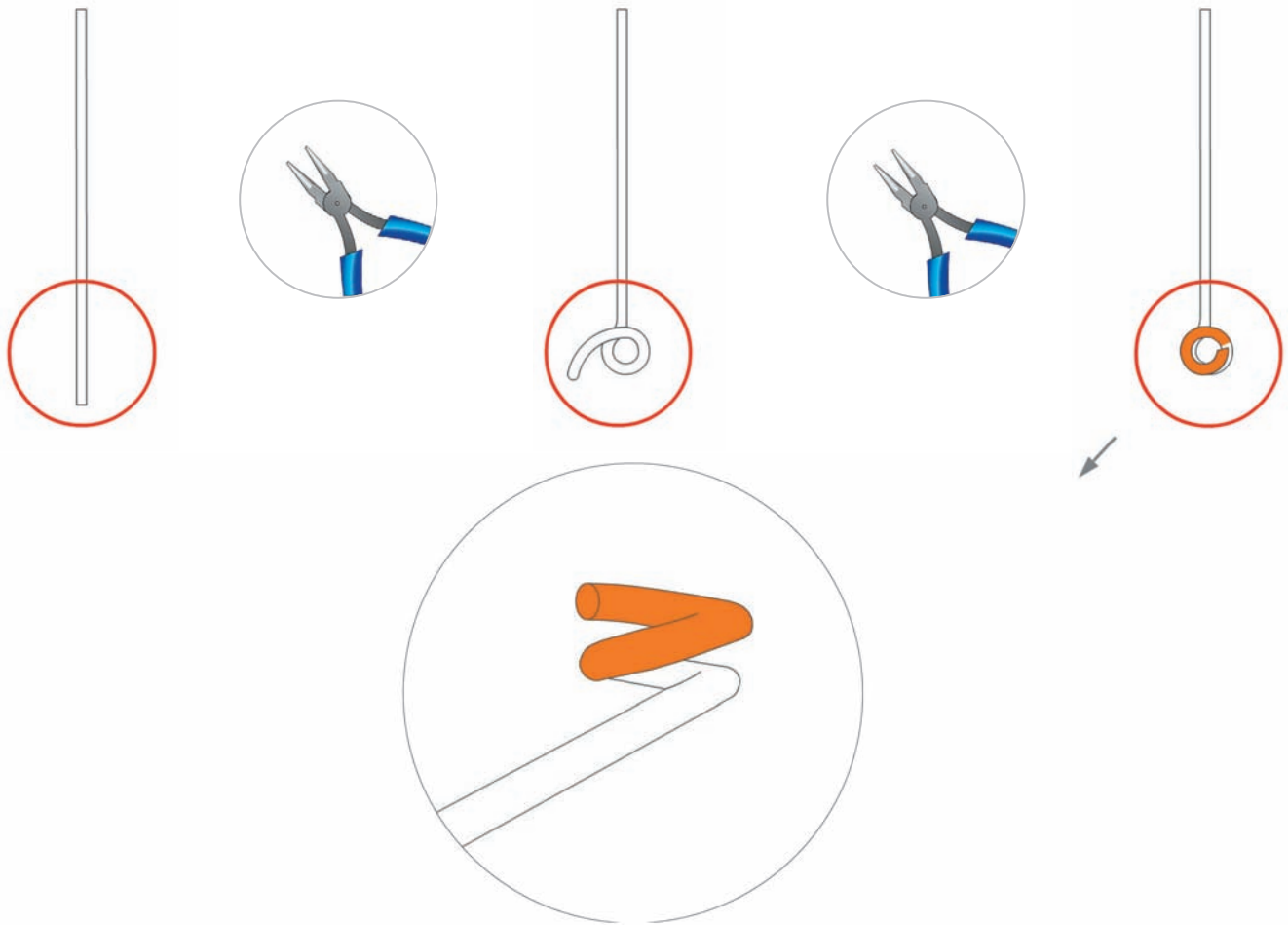

STEP 8

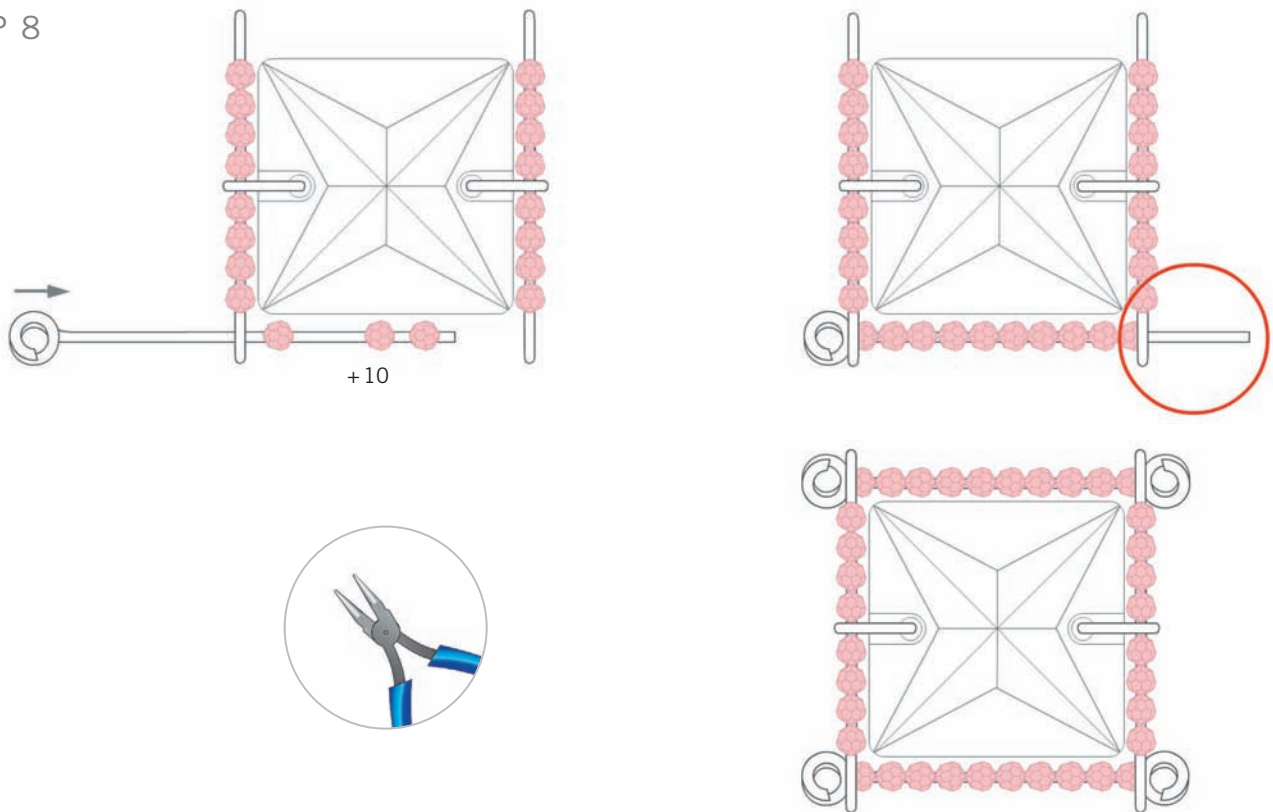

STEP 9

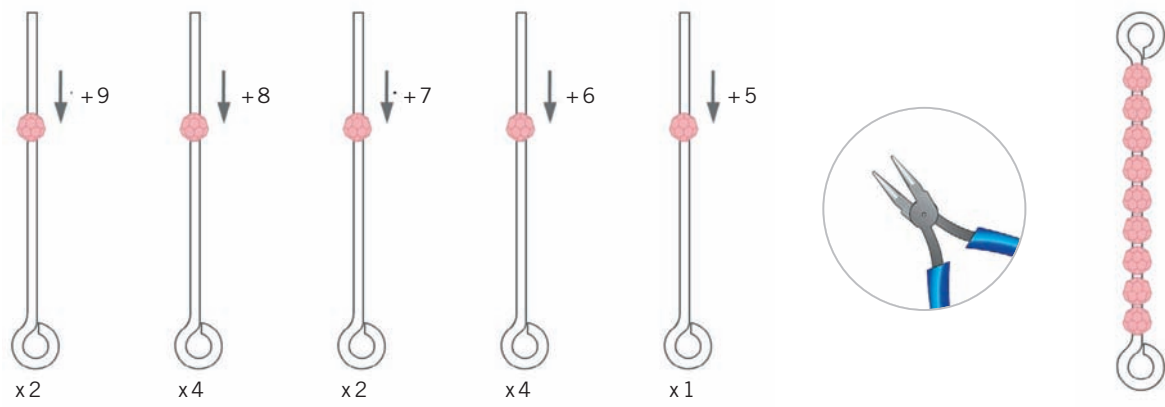

STEP 10

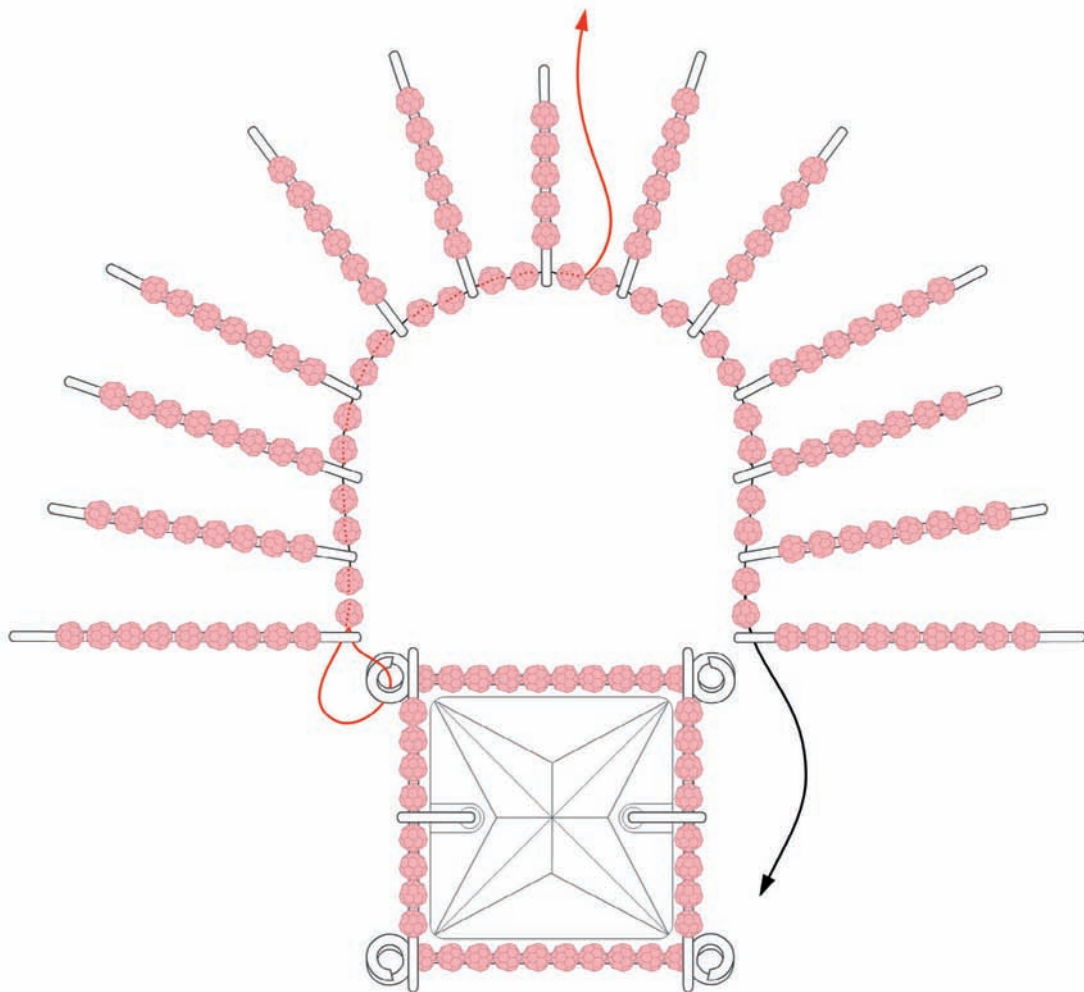

STEP 11

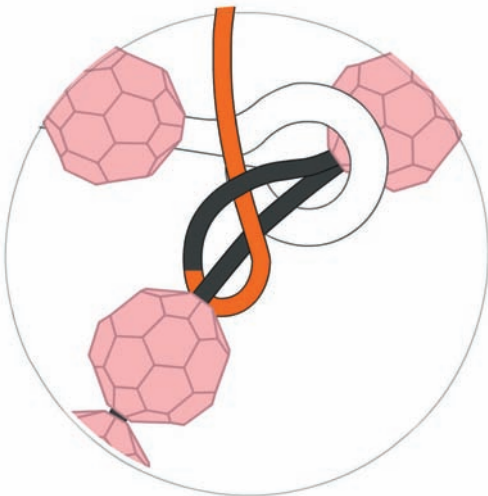
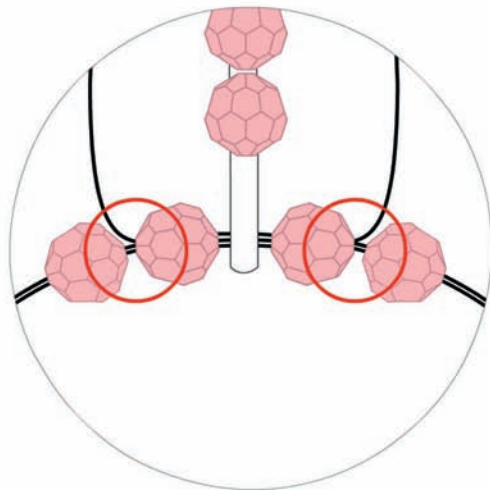
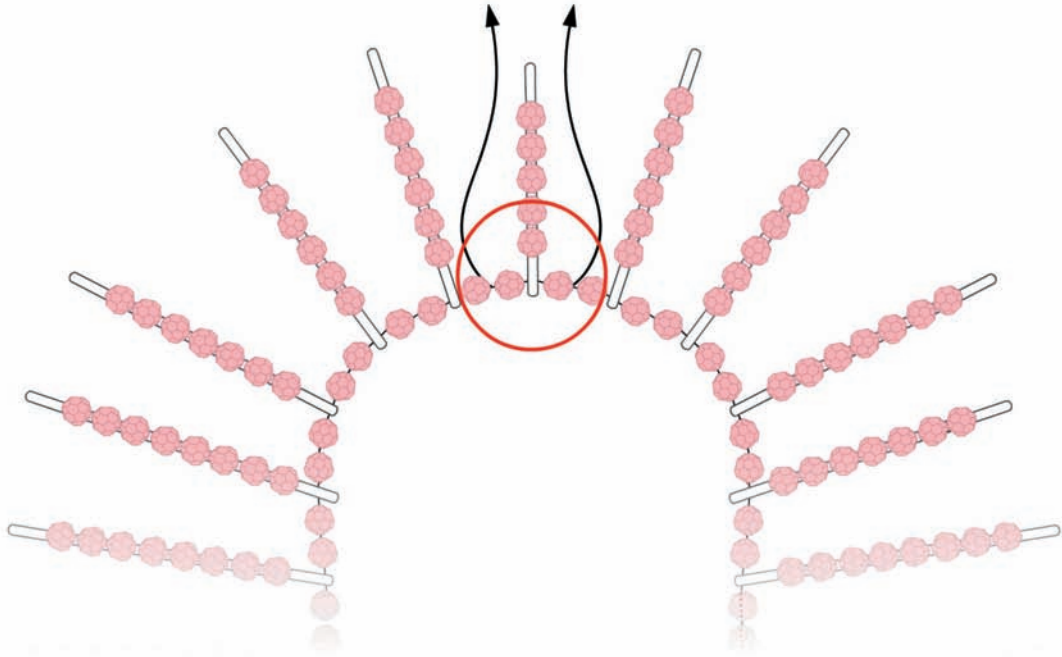

STEP 12

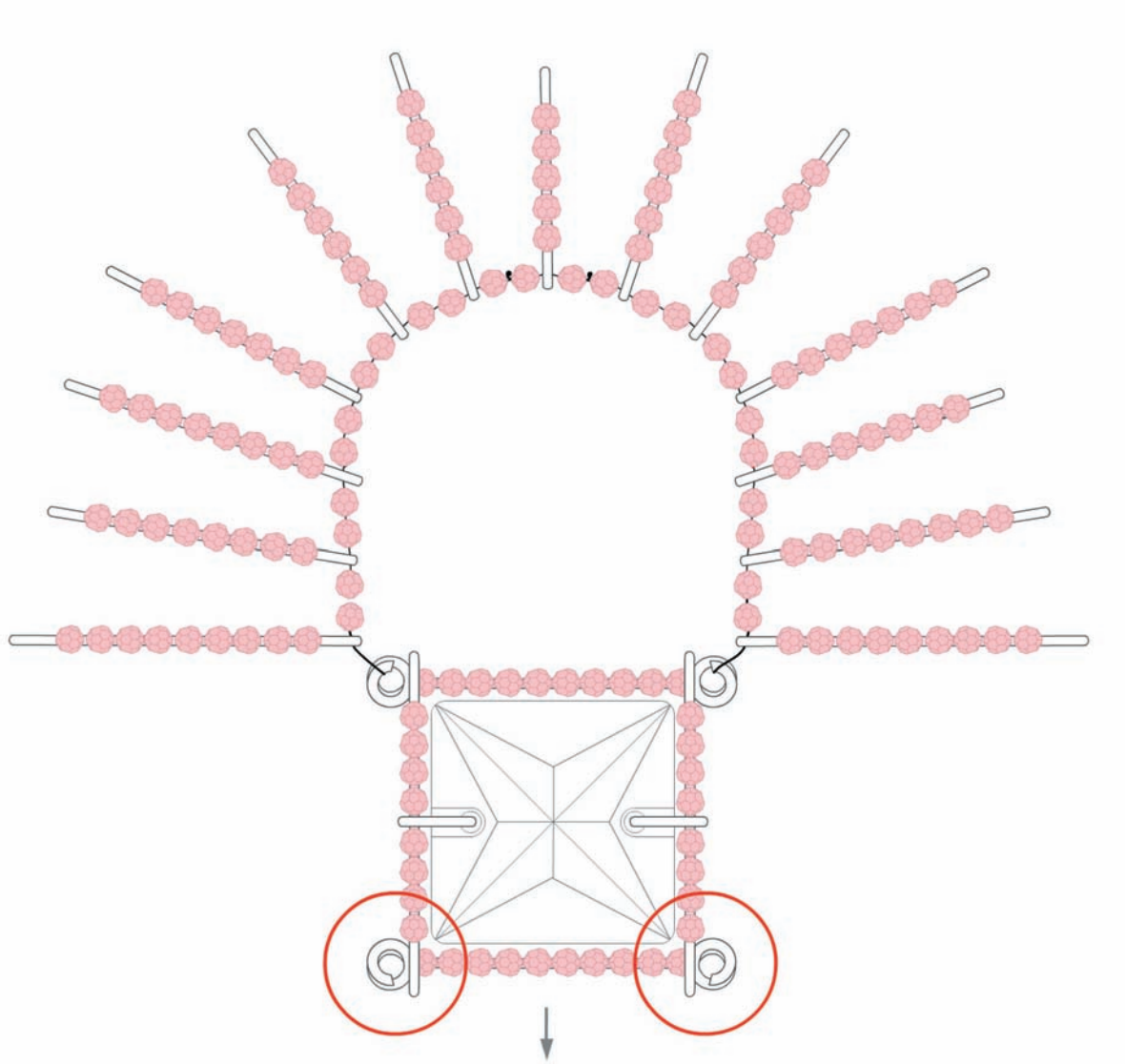

Repeat steps 9-11